

**CIVIL ENGINEERING**  
**Paper – I**

Time Allowed : **Three Hours**

Maximum Marks : **200**

**Question Paper Specific Instructions**

**Please read each of the following instructions carefully before attempting questions :**

There are **EIGHT** questions in all, out of which **FIVE** are to be attempted.

Questions no. **1** and **5** are **compulsory**. Out of the remaining **SIX** questions, **THREE** are to be attempted selecting at least **ONE** question from each of the two Sections A and B.

Attempts of questions shall be counted in sequential order. Unless struck off, attempt of a question shall be counted even if attempted partly. Any page or portion of the page left blank in the Question-cum-Answer Booklet must be clearly struck off.

All questions carry equal marks. The number of marks carried by a question/part is indicated against it.

Answers must be written in **ENGLISH** only.

Unless otherwise mentioned, symbols and notations have their usual standard meanings.

Assume suitable data, if necessary and indicate the same clearly.

Neat sketches may be drawn, wherever required.

## SECTION A

- Q1.** (a) A force of 100 N is directed along the line that is drawn from the point A(5, 2, -1) m to the point B(3, -4, 7) m. Determine the moment of this force about the 'z'-axis. 8
- (b) If two pieces of materials 'A' and 'B' have the same bulk modulus, but the value of Modulus of Elasticity for 'B' is 1% greater than that for 'A', find the value of Modulus of Rigidity for the material 'B' in terms of Modulus of Elasticity and Modulus of Rigidity for material 'A'. 8
- (c) A cantilever beam 'AB' of length 4 m is subjected to a concentrated load of 2 kN and a couple of 0.5 kNm acting at the free end as shown in the figure below. Determine the slope and deflection at the free end using Moment Area Method. 8

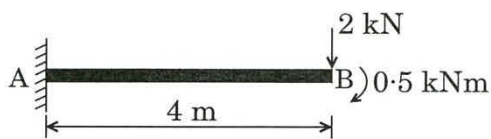

- (d) A simply supported beam of a beam and slab system, rests on a support of width 380 mm. The clear span of the beam is 10.5 m. The thickness of the slab is 125 mm. The width of the beam is 250 mm and the depth of the beam below the slab is 475 mm. The beam is reinforced with one row of 25 mm diameter steel reinforcements of grade Fe 415. The total load including the superimposed dead load, live load and its own weight is 35 kN/m at service stage. Compute the maximum ultimate design shear stress in concrete. 8
- (e) The diameter of a ring beam in a water tank is 12.5 m. It is subjected to an outward radial force of 25 kN/m. Design the section using M 25 grade of concrete and Fe 415 steel. Take  $m = 11$  and the allowable stress in concrete in tension is  $1.2 \text{ N/mm}^2$ . 8
- Q2.** (a) A uniform T-section beam is 100 mm wide and 150 mm deep with a flange thickness of 25 mm and a web thickness of 12 mm. If the limiting bending stresses for the material of the beam are  $80 \text{ MN/m}^2$  in compression and  $160 \text{ MN/m}^2$  in tension, find the maximum U.D.L. that the beam can carry over a simply supported span of 5 m. 10

- (b) A steel column consisting of ISMB 350 is effectively restrained at mid-height by a bracing member in Y-Y direction, but is free to move in Z-Z direction and both the ends of the column are pinned. Its unsupported length is 6 m. Determine its axial load carrying capacity at service loads, using the limit state design of IS : 800 – 2007.

15

$$\text{Design compressive strength } f_{cd} = \frac{f_y / \gamma_{m0}}{\phi + [\phi^2 - \lambda^2]^{0.5}},$$

$$\text{where } \phi = 0.5[1 + \alpha(\lambda - 0.2) + \lambda^2]$$

$$\lambda = \sqrt{\frac{f_y}{f_{cc}}}$$

$$\text{Euler buckling stress } f_{cc} = \frac{\pi^2 E}{\left(\frac{KL}{r}\right)^2}$$

and  $\alpha = 0.34$  for buckling class 'b'

= 0.21 for buckling class 'a'

$$f_y = 250 \text{ N/mm}^2$$

$$\gamma_{m0} = 1.10 \text{ and } \gamma_f = 1.5$$

$$E = 2 \times 10^5 \text{ N/mm}^2$$

Minimum radius of gyration for ISMB 350 is given below :

$$r_{yy} = 28.4 \text{ mm}$$

$$r_{xx} = 142.9 \text{ mm}$$

Area of cross-section of the ISMB 350 is  $6671 \text{ mm}^2$ .

- (c) In the framed structure shown in the figure below, if the length of all the members is the same, determine the force in the member 'DE' using the Virtual Work Method.

10

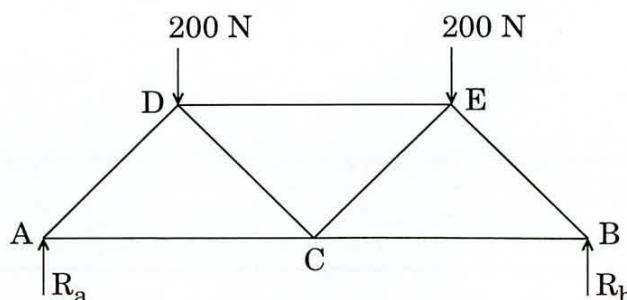

- (d) A railway wagon weighs 0.25 MN when empty and 0.6 MN when loaded. The springs of the wagon get compressed by 8 cm when it is full. Determine the natural period of vibration when the wagon is empty and when it is loaded.

5

- Q3. (a) A welded bracket connects a plate to the column flanges as shown in the figure. Determine the size of weld if the allowable stress in the weld is  $110 \text{ N/mm}^2$ .

15

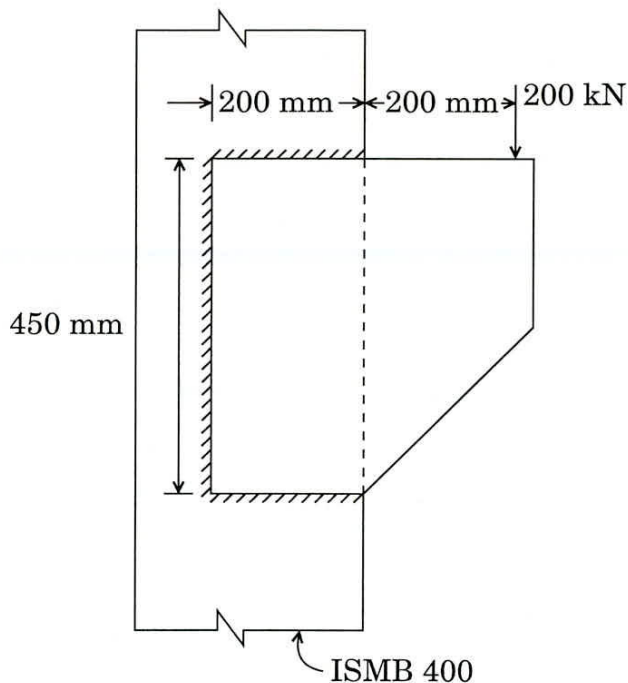

- (b) A simply supported beam of span 8 m is subjected to a series of rolling loads as shown. Determine the position of loads and the absolute maximum Bending Moment.

15

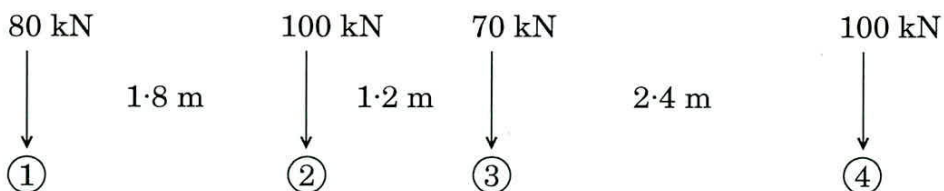

- (c) A beam with a rectangular cross-section of size 250 mm wide and 500 mm deep is prestressed by a force of 500 kN using 8 Nos. of 7 mm  $\phi$  steel cables located at an eccentricity of 80 mm. Find the loss of prestress due to creep of concrete. Grade of concrete is M 40. Coefficient of creep is taken as 1.8. Modulus of Elasticity of steel  $E_s$  is  $2 \times 10^5 \text{ N/mm}^2$ . Assume the stress at transfer is 80%.

10

- Q4. (a) A continuous beam ABC is loaded as shown in the figure below. Determine the required Plastic Moment ( $M_P$ ) of the beam section if the load factor is 3.2.

15

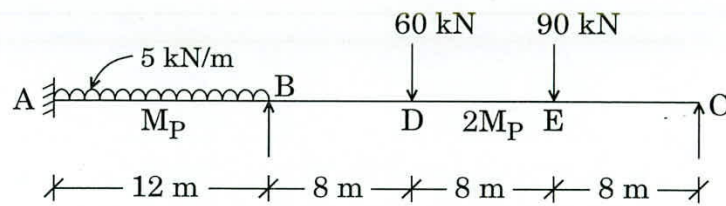

- (b) A masonry retaining wall, trapezoidal section is 1.2 m wide at the top. Its earth retaining face is vertical and smooth. The retained earth, having density of  $16 \text{ kN/m}^3$  and angle of shearing resistance of  $30^\circ$ , is level with the top of the wall. Height of the wall is 6.9 m. The density of masonry is  $19.5 \text{ kN/m}^3$ . Calculate the maximum bottom width of the wall, so that no tension is to be developed at the base. Also calculate the maximum base pressure at this width.
- (c) Two ISA  $90 \times 90 \times 8 \text{ mm}$  carry a load of 180 kN and are placed back to back through 8 mm gusset plate. The permissible shear stress is  $110 \text{ N/mm}^2$  and bearing stress is  $250 \text{ N/mm}^2$ . Design the riveted connection and show the arrangement with a neat sketch.

15

10

## SECTION B

- Q5. (a) The velocity potential for a two-dimensional flow is  $\phi = x(2y - 1)$ . Determine the value of stream function at a point P(4, 5). Comment whether the flow is rotational or irrotational. Also determine the velocity at the point P(4, 5). 8
- (b) A three-cylinder car has pistons of 75 mm and cylinders of 75 mm. Find the percentage change in force required to drive the piston, when the lubricant warms from 25°C to 100°C. The dynamic viscosity of the lubricant at 25°C is 2 Ns/m<sup>2</sup> and at 100°C, it is 0.4 Ns/m<sup>2</sup>. 8
- (c) A soil sample is tested in the laboratory for classification. The test results are as follows :
- Percentage passing 4.75 mm IS sieve = 58
- Percentage passing 75  $\mu$  IS sieve = 11
- The particle size  $D_{60} = 6.3$  mm
- $D_{30} = 0.5$  mm
- $D_{10} = 0.07$  mm
- Liquid limit = 42
- Plastic limit = 21
- Classify the soil. 8
- (d) A constant head permeability test was run on a sand sample 400 mm long and 3000 mm<sup>2</sup> in area. When the loss of head was 900 mm, the quantity of water collected in 3 minutes was 400 ml.
- (i) Determine the coefficient of permeability of the soil.
- (ii) If the specific gravity of grains is 2.65 and the dry mass of the sample is 1.9 kg, find the void ratio of the sample. 8
- (e) Compare the salient features of Standard Penetration Test and Plate Load Test. 8

- Q6.** (a) Find the hydraulic efficiency of a Pelton turbine operating under a head of 350 m, with a discharge of  $15 \text{ m}^3/\text{s}$ . 15
- The other data are :
- Speed ratio  $K_u = 0.46$
- Coefficient of velocity  $C_v = 0.985$
- $V_{r_2} = 0.9 V_{r_1}$  and  $\phi = 20^\circ$
- (b) A raft of size  $4 \text{ m} \times 4 \text{ m}$  carries a uniform load of  $200 \text{ kN/m}^2$ . Find the stress at 6 m below the raft centre considering both geostatic stress and induced stress. Use point load approximation with four equivalent point loads. Take  $\gamma_{\text{soil}} = 20 \text{ kN/m}^3$ . 15
- (c) There is a bed of compressible clay of 3 m thickness with pervious sand on top and impervious rock at the bottom. In a consolidation test on an undisturbed specimen of this clay, 90% settlement is reached in 6 hours. The specimen was 20 mm thick. Estimate the time in years for the building, founded over this deposit, to reach 90% of its final settlement. 10
- Q7.** (a) What is hydraulic jump ? Explain the uses of hydraulic jump in brief. Derive the equation for sequent depth ratio, for a hydraulic jump in a horizontal rectangular channel. What are the assumptions used in deriving the sequent depth ratio ? 10
- (b) A rectangular channel is 4.0 m wide and conveys a discharge of  $20 \text{ m}^3/\text{s}$  at a depth of 2.2 m. It is proposed to reduce the width of the channel at a hydraulic structure. Assuming the transition to be horizontal and the flow to be frictionless, determine the water surface elevations upstream and downstream of the constriction when the constricted width is 2.8 m. 15
- (c) A gravity retaining wall retains 12 m of backfill,  $\gamma = 18 \text{ kN/m}^3$ ,  $\phi = 30^\circ$  with a uniform horizontal surface. Assuming the wall interface to be vertical, determine the magnitude and point of application of total active pressure. If the water table is 3 m below the ground surface, how far do the magnitude and point of application of active pressure change ? Assume submerged unit weight of soil as  $11 \text{ kN/m}^3$ . 15

- Q8. (a) Two reservoirs 10 km apart have a difference of water level of 25 m and are connected together by a pipeline. The pipeline consists of a 6 km single pipe feeding a junction from which two pipes run in parallel for the remaining length of 4 km to the lower reservoir. If the same size of pipe is used throughout, what should be the diameter for the pipe so that velocity may not exceed 1.25 m/s ? Take the friction coefficient  $f = 0.03$ . 15
- (b) For the following data, compute the settlement of the group assuming the load to be transferred at two-thirds the length of a pile :  
Depth of clay layer = 16 m, load on piles = 2000 kN, length of piles = 10.5 m, diameter of a pile = 0.45 m, spacing of piles = 1.25 m c/c, number of piles = 16, initial void ratio = 0.80,  $C_c = 0.45$  and unit weight of soil =  $16.5 \text{ kN/m}^3$ . Take size of pile cap  $5.65 \times 5.65 \text{ m}$ . 15
- (c) A pipe of diameter 1.5 m is required to transport an oil of specific gravity 0.9 and viscosity  $3 \times 10^{-2}$  poise at the rate of 3000 litres/s. Tests were conducted on a 15 cm diameter pipe using water at 20°C. Find the velocity and rate of flow in the model. Viscosity of water at 20°C is 0.01 poise. 10