

PHYSICS

Paper – II

Time Allowed : **Three Hours**

Maximum Marks : **200**

Question Paper Specific Instructions

Please read each of the following instructions carefully before attempting questions :

There are **EIGHT** questions in all, out of which **FIVE** are to be attempted.

Questions no. **1** and **5** are **compulsory**. Out of the remaining **SIX** questions, **THREE** are to be attempted selecting at least **ONE** question from each of the two Sections A and B.

Attempts of questions shall be counted in sequential order. Unless struck off, attempt of a question shall be counted even if attempted partly. Any page or portion of the page left blank in the Question-cum-Answer Booklet must be clearly struck off.

All questions carry equal marks. The number of marks carried by a question/part is indicated against it.

Answers must be written in **ENGLISH** only.

Unless otherwise mentioned, symbols and notations have their usual standard meanings.

Assume suitable data, if necessary and indicate the same clearly.

Neat sketches may be drawn, wherever required.

Useful Constants :

Mass of proton	=	1.673×10^{-27} kg		
Mass of neutron	=	1.675×10^{-27} kg		
Mass of electron	=	9.11×10^{-31} kg		
Planck constant	=	6.626×10^{-34} Js		
Boltzmann constant	=	1.380×10^{-23} JK ⁻¹		
Bohr magneton (μ_B)	=	9.273×10^{-24} A m ²		
Nuclear magneton (μ_N)	=	5.051×10^{-27} JT ⁻¹ (A m ²)		
Electronic charge	=	1.602×10^{-19} C		
Atomic mass unit (u)	=	1.660×10^{-27} kg		
	=	931 MeV		
g_s^p	=	$5.5855 \mu_N$	$m(p)$	= 1.00727 u
$m(n)$	=	1.00866 u	$m({}_2^4\text{He})$	= 4.002603 u
$m({}_6^{12}\text{C})$	=	12.00000 u	$m({}_{38}^{87}\text{Sr})$	= 86.908893 u
$m({}_1^2\text{H})$	=	2.014022 u	$m({}_1^3\text{H})$	= 3.0160500 u
$m({}_8^{16}\text{O})$	=	15.999 u		
\hbar	=	1.05×10^{-34} Js		
hc	=	197 eVnm		

SECTION A

- Q1. (a) Use uncertainty principle to estimate the ground state energy of a linear harmonic oscillator. 8
- (b) Consider an electron circulating around a proton (as shown in figure) in a circular orbit of radius, r . Assuming the motion of orbiting electron equivalent to an electrical current loop, find the expression for the ratio of magnetic moment to the angular momentum of the system and estimate the numerical value of this ratio. 8

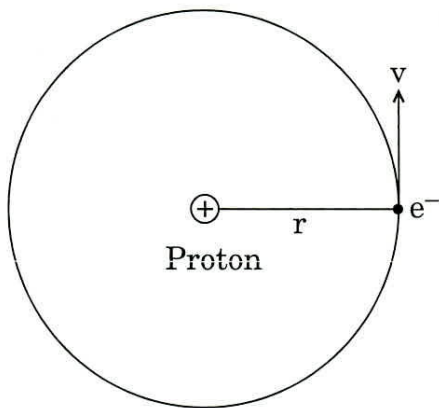

- (c) Electrons with energies of 1.0 eV and 2.0 eV are incident on a barrier 10.00 eV high and 0.50 nm (nanometer) wide. Calculate the ratio of their respective transmission probabilities across the barrier. 8

- (d) In an atomic physics experiment a beam of p-state atoms is passed through a non-uniform magnetic field. After passing through the magnetic field the atomic beam strikes at the screen and is detected as shown in the given figure.

Obtain an expression of the force acting on the p-atoms beam due to gradient in the magnetic field acting along z-axis as shown. Also comment on the number of spots that are found on the screen as an outcome and explain.

4+4

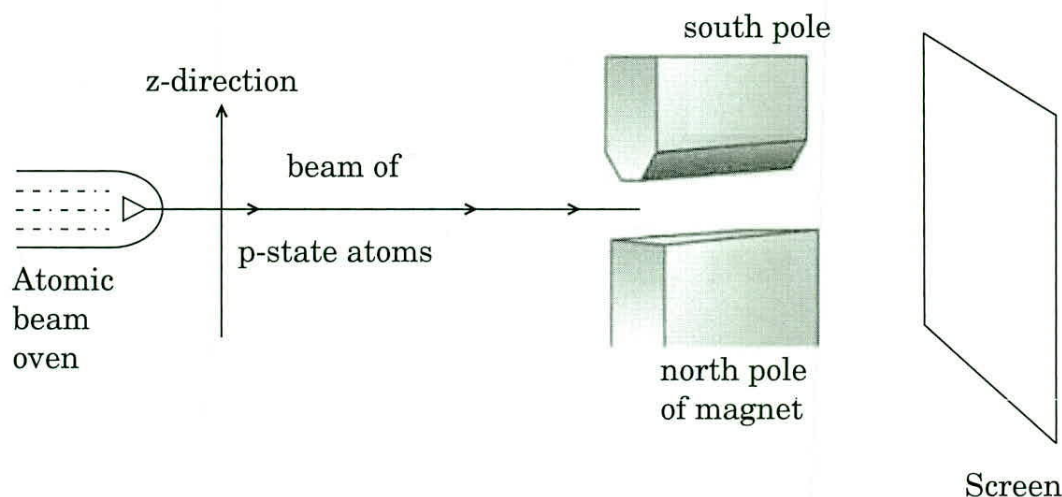

- (e) Given the time dependent one-dimensional Schrödinger wave equation as

$$H\psi(t) = i\hbar \frac{\partial \psi(t)}{\partial t}, \text{ with } H = \frac{\vec{p} \cdot \vec{p}}{2m} + V(\vec{x})$$

as Hermitian operator for a particle of momentum \vec{p} under the influence of a potential $V(\vec{x})$. Find the value of $\frac{d}{dt} \left(\int \psi^*(t) \psi(t) dx \right)$.

8

- Q2.** (a) How many different wavelengths may be observed in the spectrum from a hydrogen sample, if the atoms are excited to states with principle quantum number n ?

5

- (b) The radial part of Schrödinger wave function for hydrogen atom for spherical symmetric potential $V(r) = -\frac{e^2}{4\pi\epsilon_0 r}$ is given as :

$$\frac{1}{r^2} \frac{d}{dr} \left(r^2 \frac{dR}{dr} \right) + \frac{2\mu}{\hbar^2} \left[E - V(r) - \frac{\hbar^2 l(l+1)}{2\mu r^2} \right] R = 0,$$

where $\mu = \frac{mM}{m+M}$ is reduced mass and m and M are mass of electron and proton respectively.

- (i) Obtain the form of the above equation for ground state electron of hydrogen atom.
- (ii) Also starting with a trial wave function for the radial equation, $R = A e^{-r/a_0}$, for the $l = 0$ state, find the expressions of energy E and orbital radius for the ground state of hydrogen atom. 5+15=20

- (c) The quantum theory describes the angular momentum (\tilde{J}) as a linear operator with three components J_x , J_y and J_z in three dimensions. For the angular momentum operator prove that $[J^2, J_i] = 0$, where $i = x, y$, and z and comment on the measurability of J^2 and its components as operators. 15

- Q3.** (a) Write down the Schrödinger wave equation for a one-dimensional harmonic oscillator in which a particle of mass m and frequency ω is subject to a parabolic potential $V(x) = m\omega^2 x^2/2$. Let one of the possible energy eigen states be given by $\psi(x) = Ax e^{-x^2/x_0^2}$. Find the energy E corresponding to the eigen state given by $\psi(x)$. Is it a ground state energy or one of the excited state energies? Comment. 20

- (b) Consider an experiment in which a beam of electrons is directed at a plate containing two slits, labelled as A and B. Beyond the plate is a screen, where electrons hit the screen and are detected. For each of the following cases sketch the variation of the relative number of incident electrons as a function of position along the screen and also provide brief explanation about each observation :

- (i) Slit A open, slit B closed,
- (ii) Both A and B are open. 10

- (c) Consider a particle trapped in a box of width L and its n^{th} state wave function is given by $\psi_n(x) = \sqrt{\frac{2}{L}} \sin\left(\frac{n\pi x}{L}\right)$. Calculate the expectation value of the position $\langle x \rangle$ of the particle. How is this result different from classical consideration of finding the particle inside the box? 10

- Q4.** (a) Show that for pure rotational spectrum of a diatomic molecule the wave number difference between the consecutive lines

$$\Delta \bar{\nu} = \frac{\hbar}{2\pi I C}, \text{ where } I \text{ is the moment of inertia.} \quad 20$$

- (b) If $\Delta \bar{\nu} = 4050 \text{ m}^{-1}$ for the HF molecule, what is the interatomic distance of this molecule? [Given $\hbar = 1.05 \times 10^{-34} \text{ Js}$] 10

- (c) The most intense vibrational bands of CO and HCl molecules have the wave numbers $2.143 \times 10^5 \text{ m}^{-1}$ and $2.886 \times 10^5 \text{ m}^{-1}$ respectively. Calculate the force constants of these molecules. 10

SECTION B

- Q5.** (a) The nuclear radius of ${}_8\text{O}^{16}$ is 3 fermi. What will be the nuclear radius of U^{235} ? 8
- (b) Draw the baryon octet according to Murray Gell-Mann. 8
- (c) Show that the probability of occupation for an electron state at the Fermi energy is equal to 0.5 for all finite temperatures. 8
- (d) A small magnet is placed on the surface of a disc of normal material. Explain what happens when the disc is cooled down so that it becomes superconducting. Can this be explained from classical viewpoint if we simply treat the superconductor as a material which has zero resistivity? 8
- (e) Find the output voltage of the three-input adder circuit shown below. 8

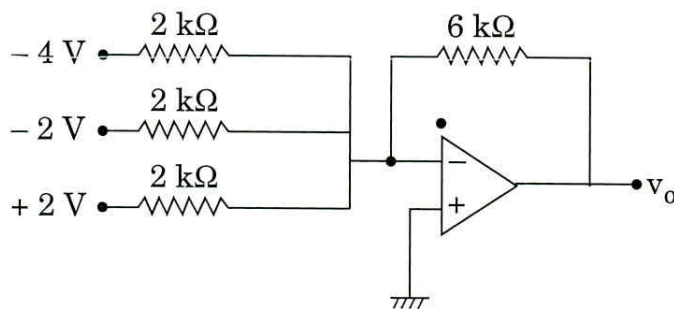

- Q6.** (a) What is the source of the Sun's energy? Explain with proper nuclear reaction. 10
- (b) What do you mean by nuclear reactors? With a neat diagram, describe the essential parts of a nuclear reactor and discuss about its applications. 20
- (c) An atomic power reactor can deliver 300 MW. If due to fission of each atom of ${}_{92}\text{U}^{235}$, the energy released is 200 MeV, calculate the mass of uranium fissioned per hour. 10

- Q7.** (a) Explain drift velocity, mobility and conductivity of an intrinsic semiconductor. 5
- (b) Calculate the total conductivity in an intrinsic semiconductor. How does this conductivity change with temperature? 15
- (c) Derive the expression for electron concentration in the conduction band of an intrinsic semiconductor. 20
- Q8.** (a) Draw the circuit of a phase shift oscillator using transistor. Obtain the expression for the frequency of oscillations and condition for sustained oscillations. Give necessary equivalent circuit while deriving the expression of frequency of oscillations and condition for sustained oscillations. 20
- (b) A pair of transistors operates in a class B push-pull circuit with a power supply of voltage $V_{cc} = 12$ V. If the turns ratio of the output transformer is 2 and the load resistance R_L is 6Ω , calculate the maximum output power and maximum dc power supplied. Hence find efficiency of the circuit. Neglect transformer winding resistance. 10
- (c) Estimate the current gain of an n-p-n transistor if only 0.3% of the conduction electrons that enter the base from the emitter recombine in the base region. 10

