



5. A body of mass 5 kg is thrown vertically up with a kinetic energy of 490 J. The height at which the kinetic energy of the body becomes half of the original value is .....

- 1) 12.5 m                      2) 10 m                      3) 2.5 m                      4) 5 m

**Ans: (4)**

6. A solid sphere of mass  $m$  rolls down an inclined plane without slipping, starting from rest at the top of an inclined plane. The linear speed of the sphere at the bottom of the inclined plane is  $v$ . The kinetic energy of the sphere at the bottom is .....

- 1)  $\frac{7}{10} mv^2$                       2)  $\frac{2}{5} mv^2$                       3)  $\frac{5}{3} mv^2$                       4)  $\frac{1}{2} mv^2$

**Ans: (1)**

7. Two satellites of mass  $m$  and  $9m$  are orbiting a planet in orbits of radius  $R$ . Their periods of revolution will be in the ratio of .....

- 1) 1: 3                      2) 1: 1                      3) 3: 1                      4) 9: 1

**Ans: (2)**

8. The following four wires of length  $L$  and radius  $r$  are made of the same material. Which of these will have the largest extension, when the same tension is applied?

- 1)  $L = 400$  cm,  $r = 0.8$  mm                      2)  $L = 300$  cm,  $r = 0.6$  mm  
2)  $L = 200$  cm,  $r = 0.4$  mm                      4)  $L = 100$  cm,  $r = 0.2$  mm

**Ans: (4)**

9. The resultant of two forces acting at an angle of  $120^\circ$  is 10 kg wt and is perpendicular to one of the forces. That force is .....

- 1)  $\frac{10}{\sqrt{3}}$  kg wt                      2) 10 kg wt                      3)  $20\sqrt{3}$  kg wt                      4)  $10\sqrt{3}$  kg wt

**Ans: (1)**

10. Eight equal drops of water are falling through air with a steady velocity of  $10 \text{ cm s}^{-1}$ . If the drops combine to form a single drop big in size, then the terminal velocity of this big drop is .....

- 1)  $80 \text{ cm s}^{-1}$                       2)  $30 \text{ cm s}^{-1}$                       3)  $10 \text{ cm s}^{-1}$                       4)  $40 \text{ cm s}^{-1}$

**Ans: (4)**

11. Two capillary tubes of different diameters are dipped in water. The rise of water is .....
- 1) independent of the diameter of the tube
  - 2) greater in the tube of smaller diameter
  - 3) greater in the tube of larger diameter
  - 4) the same in both tubes

**Ans: (2)**

12. A perfect gas at  $20^{\circ}\text{C}$  is heated at constant pressure so as to double its volume. The increase in temperature of the gas will be .....
- 1)  $300^{\circ}\text{C}$
  - 2)  $54^{\circ}\text{C}$
  - 3)  $327^{\circ}\text{C}$
  - 4)  $600^{\circ}\text{C}$

**Ans: (3)**

13. Three identical rods A, B and C are placed end to end. A temperature difference is maintained between the free ends of A and C. The thermal conductivity of B is THRICE that of C and HALF of that of A. The effective thermal conductivity of the system will be ..... ( $K_A$  is the thermal conductivity of rod A).
- 1)  $\frac{2}{3} K_A$
  - 2)  $2 K_A$
  - 3)  $3 K_A$
  - 4)  $\frac{1}{3} K_A$

**Ans: (4)**

14. The quantities of heat required to raise the temperatures of two copper spheres of radii  $r_1$  and  $r_2$  ( $r_1 = 1.5 r_2$ ) through 1 K are in the ratio of .....
- 1) 1
  - 2)  $\frac{3}{2}$
  - 3)  $\frac{9}{4}$
  - 4)  $\frac{27}{8}$

**Ans: (4)**

15. Which one of the following is  $\nu_m - T$  graph for perfectly black body?  $\nu_m$  is the frequency of radiation with maximum intensity.  $T$  is the absolute temperature.
- 1) D
  - 2) C
  - 3) B
  - 4) A

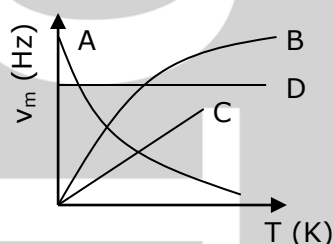

**Ans: (2)**

16. A particle executing a simple harmonic motion has a period of 6 sec. The time taken by the particle to move from the mean position to half the amplitude, starting from the mean position is

- 1)  $\frac{1}{4}$  sec      2)  $\frac{3}{4}$  sec      3)  $\frac{1}{2}$  sec      4)  $\frac{3}{2}$  sec

**Ans: (3)**

17. The equation of a wave is given by  $y = 10 \sin \left( \frac{2\pi}{45} t + \alpha \right)$ . If the displacement is 5 cm at  $t = 0$ , then the total phase at  $t = 7.5$  sec. is

- 1)  $\pi$       2)  $\frac{\pi}{6}$       3)  $\frac{\pi}{2}$       4)  $\frac{\pi}{3}$

**Ans: (3)**

18. Two tuning forks, A and B, produce notes of frequencies 258 Hz and 262 Hz. An unknown note sounded with A produces certain beats. When the same note is sounded with B, the beat frequency gets doubled. The unknown frequency is

- 1) 256 Hz      2) 254 Hz      3) 300 Hz      4) 250 Hz

**Ans: (2)**

19. A wire under tension vibrates with a fundamental frequency of 600 Hz. If the length of the wire is doubled, the radius is halved and the wire is made to vibrate under one-ninth the tension. Then the fundamental frequency will become

- 1) 400 Hz      2) 600 Hz      3) 300 Hz      4) 200 Hz

**Ans: (4)**

20. Faintest stars are called

- 1) dwarfs      2) sixth magnitude stars  
3) second magnitude stars      4) zero magnitude stars

**Ans: (2)**

21. Wavelength of given light waves in air and in a medium are  $6000 \text{ \AA}$  and  $4000 \text{ \AA}$  respectively. The critical angle is .....

- 1)  $\sin^{-1}\left(\frac{3}{2}\right)$       2)  $\sin^{-1}\left(\frac{2}{3}\right)$       3)  $\tan^{-1}\left(\frac{3}{2}\right)$       4)  $\tan^{-1}\left(\frac{2}{3}\right)$

**Ans: (2)**

22. The time required for the light to pass through a glass slab (refractive index = 1.5) of thickness 4 mm is ..... ( $c = 3 \times 10^8 \text{ ms}^{-1}$ , speed of light in free space).

- 1)  $2 \times 10^{-5} \text{ sec}$       2)  $2 \times 10^{+11} \text{ sec}$       3)  $2 \times 10^{-11} \text{ sec}$       4)  $10^{-11} \text{ sec}$

**Ans: (3)**

23. A prism having refractive index 1.414 and refracting angle  $30^\circ$  has one of the refracting surfaces silvered. A beam of light incident on the other refracting surface will retrace its path, if the angle of incidence is .....

- 1)  $45^\circ$       2)  $60^\circ$       3)  $30^\circ$       4)  $0^\circ$

**Ans: (1)**

24. A planoconvex lens has a maximum thickness of 6 cm. When placed on a horizontal table with the curved surface in contact with the table surface, the apparent depth of the bottommost point of the lens is found to be 4 cm. If the lens is inverted such that the plane face of the lens is in contact with the surface of the table, the apparent depth of the center of the plane face is found to be  $\left(\frac{17}{4}\right)$  cm. The radius of curvature of the lens is .....

- 1) 34 cm      2) 128 cm      3) 75 cm      4) 68 cm

**Ans: (1)**

25. Two thin lenses have a combined power of +9 D. When they are separated by a distance of 20 cm, their equivalent power becomes  $+\frac{27}{5}$  D. Their individual powers (in diopters) are .....

- 1) 4, 5      2) 3, 6      3) 2, 7      4) 1, 8

**Ans: (2)**

26. Wavefront is the locus of all points, where the particles of the medium vibrate with the same .....
- 1) period                      2) frequency                      3) amplitude                      4) phase

**Ans: (4)**

27. Two monochromatic light waves of amplitudes  $3A$  and  $2A$  interfering at a point have a phase difference of  $60^\circ$ . The intensity at the point will be proportional to .....
- 1)  $19 A^2$                       2)  $7 A^2$                       3)  $13 A^2$                       4)  $5 A^2$

**Ans: (1)**

28. Consider the following statements in case of Young's double slit experiment.
- a) A slit  $S$  is necessary if we use an ordinary extended source of light.
- b) A slit  $S$  is not needed if we use an ordinary but well collimated beam of light.
- c) A slit  $S$  is not needed if we use a spatially coherent source of light.
- Which of the above statements are correct?

- 1) a) and c)                      2) b) and c)                      3) a) and b)                      4) a), b) and c)

**Ans: (1)**

29. A parallel beam of light of wavelength  $6000 \text{ \AA}$  gets diffracted by a single slit of width  $0.3 \text{ mm}$ . The angular position of the first minima of diffracted light is .....
- 1)  $6 \times 10^{-3} \text{ rad}$                       2)  $1.8 \times 10^{-3} \text{ rad}$                       3)  $3 \times 10^{-3} \text{ rad}$                       4)  $2 \times 10^{-3} \text{ rad}$

**Ans: (4)**

30. The critical angle of a certain medium is  $\sin^{-1}\left(\frac{3}{5}\right)$ . The polarizing angle of the medium is .....

- 1)  $\tan^{-1}\left(\frac{4}{3}\right)$                       2)  $\tan^{-1}\left(\frac{3}{4}\right)$                       3)  $\tan^{-1}\left(\frac{5}{3}\right)$                       4)  $\sin^{-1}\left(\frac{4}{5}\right)$

**Ans: (3)**

31. Two identical charged spheres of material density  $\rho$ , suspended from the same point by inextensible strings of equal length make an angle  $\theta$  between the strings. When suspended in a liquid of density  $\sigma$  the angle  $\theta$  remains the same. The dielectric constant  $K$  of the liquid is .....

- 1)  $\frac{\rho + \sigma}{\rho}$                       2)  $\frac{\rho}{\rho + \sigma}$                       3)  $\frac{\rho - \sigma}{\rho}$                       4)  $\frac{\rho}{\rho - \sigma}$

**Ans: (4)**

32. The electric field at a point due to an electric dipole, on an axis inclined at an angle  $\theta$  ( $< 90^\circ$ ) to the dipole axis, is perpendicular to the dipole axis, if the angle  $\theta$  is .....

- 1)  $\tan^{-1}\left(\frac{1}{\sqrt{2}}\right)$     2)  $\tan^{-1}(\sqrt{2})$     3)  $\tan^{-1}\left(\frac{1}{2}\right)$     4)  $\tan^{-1}(2)$

**Ans: (4)**

33. In the circuit shown, the currents  $i_1$  and  $i_2$  are .....

- 1)  $i_1 = 3 \text{ A}, i_2 = 1 \text{ A}$   
 2)  $i_1 = 1 \text{ A}, i_2 = 3 \text{ A}$   
 3)  $i_1 = 0.5 \text{ A}, i_2 = 1.5 \text{ A}$   
 4)  $i_1 = 1.5 \text{ A}, i_2 = 0.5 \text{ A}$

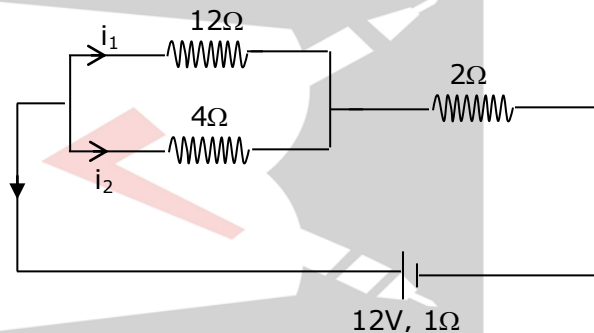

**Ans: (3)**

34. In the given network, the value of  $C$ , so that an equivalent capacitance between A and B is  $3\mu\text{F}$ , is .....

- 1)  $36 \mu\text{F}$   
 2)  $48 \mu\text{F}$   
 3)  $\frac{31}{5} \mu\text{F}$   
 4)  $\frac{1}{5} \mu\text{F}$

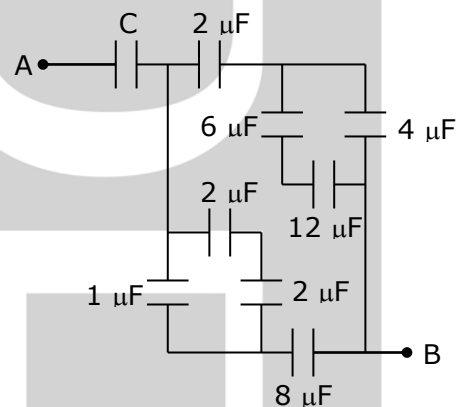

**Ans: (2)**

35. A conductor wire having  $10^{29}$  free electrons/ $\text{m}^3$  carries a current of 20 A. If the cross-section of the wire is  $1 \text{ mm}^2$ , then the drift velocity of electrons will be .....

- 1)  $6.25 \times 10^{-3} \text{ ms}^{-1}$     2)  $1.25 \times 10^{-5} \text{ ms}^{-1}$   
 3)  $1.25 \times 10^{-3} \text{ ms}^{-1}$     4)  $1.25 \times 10^{-4} \text{ ms}^{-1}$

**Ans: (3)**

36. A resistor has a colour code of green, blue, brown and silver. What is its resistance?

- 1)  $5600 \Omega \pm 10\%$     2)  $560 \Omega \pm 5\%$     3)  $560 \Omega \pm 10\%$     4)  $56 \Omega \pm 5\%$

**Ans: (3)**

37. The voltage  $V$  and current  $I$  graphs for a conductor at two different temperatures  $T_1$  and  $T_2$  are shown in the figure. The relation between  $T_1$  and  $T_2$  is .....

- 1)  $T_1 = \frac{1}{T_2}$
- 2)  $T_1 = T_2$
- 3)  $T_1 < T_2$
- 4)  $T_1 > T_2$

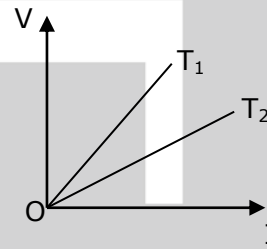

**Ans: (4)**

38. Consider the following statements regarding the network shown in the figure.

- a) The equivalent resistance of the network between points A and B is independent of value of  $G$ .
- b) The equivalent resistance of the network between points A and B is  $\frac{4}{3} R$ .
- c) The current through  $G$  is zero.

Which of the above statements is/are TRUE?

- 1) (a), (b) and (c)
- 2) (b) and (c)
- 3) (b) alone
- 4) (a) alone

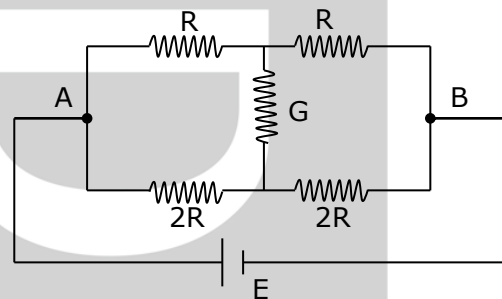

**Ans: (1)**

39. The torque required to hold a small circular coil of 10 turns, area  $1 \text{ mm}^2$  and carrying a current of  $\left(\frac{21}{44}\right) \text{ A}$  is the middle of a long solenoid of  $10^3$  turns/m carrying a current of  $2.5 \text{ A}$ , with its axis perpendicular to the axis of the solenoid is .....

- 1)  $1.5 \times 10^{-8} \text{ N-m}$
- 2)  $1.5 \times 10^{-6} \text{ N-m}$
- 3)  $1.5 \times 10^{-8} \text{ N-m}$
- 4)  $1.5 \times 10^{-6} \text{ N-m}$

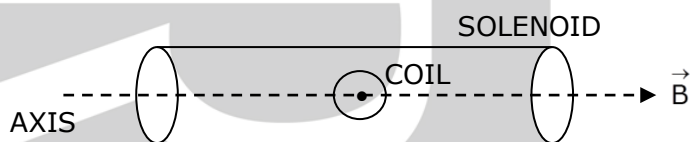

**Ans: (3)**

40. A particle of charge  $e$  and mass  $m$  moves with a velocity  $v$  in a magnetic field  $B$  applied perpendicular to the motion of the particle. The radius  $r$  of its path in the field is .....

- 1)  $\frac{Bv}{em}$
- 2)  $\frac{ev}{Bm}$
- 3)  $\frac{Be}{mv}$
- 4)  $\frac{mv}{Be}$

**Ans: (4)**

41. A neutron, a proton, an electron and an  $\alpha$  - particle enter a region of uniform magnetic field with the same velocities. The magnetic field is perpendicular and directed into the plane of the paper. The tracks of the particles are labelled in the figure. The electron follows the track

- 1) D
- 2) C
- 3) B
- 4) A

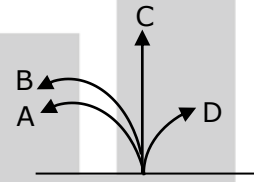

**Ans: (1)**

42. The deflection in a moving coil galvanometer is reduced to half when it is shunted with a  $40 \Omega$  coil. The resistance of the galvanometer is

- 1)  $15 \Omega$
- 2)  $20 \Omega$
- 3)  $40 \Omega$
- 4)  $80 \Omega$

**Ans: (3)**

43. A current of  $\left(\frac{2}{\sqrt{3}}\right)$  A produces a deflection of  $60^\circ$  in a tangent galvanometer. The reduction factor is

- 1)  $\left(\frac{3}{2}\right)$  A
- 2) 2A
- 3)  $\left(\frac{2}{3}\right)$  A
- 4)  $\left(\frac{2}{\sqrt{3}}\right)$  A

**Ans: (3)**

44. In an A.C. circuit, V and I are given by  $V = 150 \sin (150t)$  volt and  $I = 150 \sin \left(150t + \frac{\pi}{3}\right)$  ampere. The power dissipated in the circuit is

- 1) zero
- 2) 5625 W
- 3) 150 W
- 4) 106 W

**Ans: (2)**

45. In the L-C-R circuit shown, the impedance is

- 1)  $500 \Omega$
- 2)  $300 \Omega$
- 3)  $100 \Omega$
- 4)  $200 \Omega$

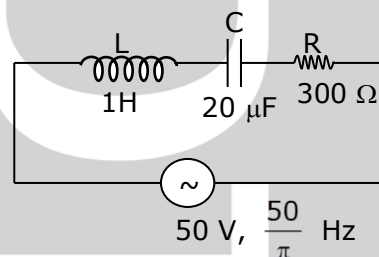

**Ans: (1)**

46. The energy stored in an inductor of self inductance L henry carrying a current of I ampere is

- 1)  $L^2 I$
- 2)  $LI^2$
- 3)  $\frac{1}{2} LI^2$
- 4)  $\frac{1}{2} L^2 I$

**Ans: (3)**

47. A transformer works on the principle of

- 1) magnetic effect of the electrical current      2) mutual induction  
3) electrical inertia      4) self induction

**Ans: (2)**

48. Flash spectrum confirms a/an

- 1) magnetic storm      2) earthquake      3) lunar eclipse      4) total solar eclipse

**Ans: (4)**

49. The photoelectric threshold wavelength for silver is  $\lambda_0$ . The energy of the electron ejected from the surface of silver by an incident wavelength  $\lambda$  ( $\lambda < \lambda_0$ ) will be

- 1)  $hc \left( \frac{\lambda_0 - \lambda}{\lambda\lambda_0} \right)$       2)  $\frac{h}{c} \left( \frac{\lambda_0 - \lambda}{\lambda\lambda_0} \right)$       3)  $\frac{hc}{\lambda_0 - \lambda}$       4)  $hc(\lambda_0 - \lambda)$

**Ans: (1)**

50. Rutherford's atomic model could account for

- 1) concept of stationary orbits  
2) the positively charged central core of an atom  
3) origin of spectra  
4) stability of atoms

**Ans: (2)**

51. When an electron jumps from the orbit  $n = 2$  to  $n = 4$ , then wavelength of the radiations absorbed will be \_\_\_\_\_ (R is Rydberg's constant).

- 1)  $\frac{3R}{16}$       2)  $\frac{5R}{16}$       3)  $\frac{16}{5R}$       4)  $\frac{16}{3R}$

**Ans: (4)**

52. The thermonuclear reaction of hydrogen inside the stars is taking place by a cycle of operations. The particular element which acts as catalyst is

- 1) carbon      2) helium      3) oxygen      4) nitrogen

**Ans: (1)**

53. The ratio of minimum wavelength of Lyman and Balmer series will be
- 1) 10                      2) 5                      3) 0.25                      4) 1.25

**Ans: (3)**

54. The fraction of the initial number of radioactive nuclei which remain undecayed after half of a half-life of the radioactive sample is

- 1)  $\frac{1}{\sqrt{2}}$                       2)  $\frac{1}{2}$                       3)  $\frac{1}{2\sqrt{2}}$                       4)  $\frac{1}{4}$

**Ans: (1)**

55. 1 curie represents
- 1) 1 disintegration per second                      2)  $10^6$  disintegrations per second
- 3)  $3.7 \times 10^{10}$  disintegrations per second                      4)  $3.7 \times 10^7$  disintegrations per second

**Ans: (3)**

56. An n-p-n transistor can be considered to be equivalent to two diodes, connected. Which of the following figures is the CORRECT ONE?



**Ans: (3)**

57. In the case of forward biasing of a p-n junction diode, which one of the following figures correctly depicts the direction of conventional current (indicated by an arrow mark)?

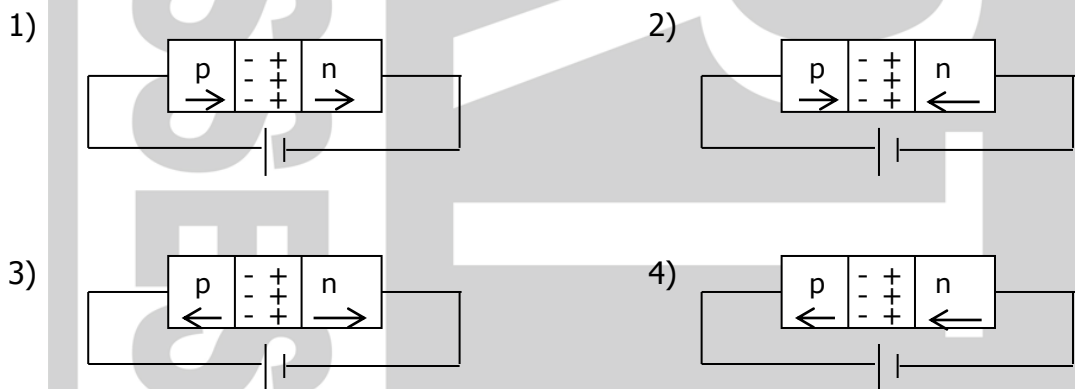

**Ans: (1)**

58. An electron of mass  $m_e$  and a proton of mass  $m_p$  are moving with the same speed. The ratio of their de-Broglie's wavelength  $\lambda_e/\lambda_p$  is

- 1) 918                      2)  $\frac{1}{1836}$                       3) 1836                      4) 1

**Ans: (3)**

59. The output of given logic circuit is

- 1)  $A + B + C$   
2)  $(A + B) \cdot (A + C)$   
3)  $A \cdot (B \cdot C)$   
4)  $A \cdot (B + C)$

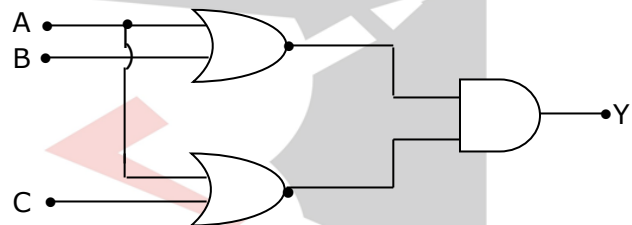

**Ans: (2)**

60. If the scattering intensity of a liquid is 8 units at a wavelength of 500 nm, then the scattering intensity at a wavelength of 400 nm will be approximately

- 1) 24 units                      2) 20 units                      2) 16 units                      4) 13 units

**Ans: (2)**